



... simply better protection!

Intercept Technology Group

Keith Donaldson

Engineered Materials, Inc.

www.Intercept-Technology.com

Joe Spitz

Liberty Packaging Company

www.LibertyPackaging.com

**2010 IEEE Reliability
May 13 Meeting - MA**

**How Carbon Footprints,
Green Initiatives and
Reliability Work Together
or Against Each Other**



Henry 5th has long held fascination with many people, including myself. His early death sent England into the depth of the 100 Years War with France, however he is remembered for his very unlikely victory at Agincourt



Its time to challenge Americans, are we going to be like the French at Agincourt, with the best army, weapons and equipment in the world, but lose to a small army with a powerful weapon, the long bow. We can either be like the French and get stuck in the mud or be like the English and embrace new tools like total cost and allow packaging to help increase equipment reliability.

Pollution is only an airstream away



Picture courtesy of AP



It's an increasingly polluted world out there

- 27% of all deaths in China are now lung related (2007)
- If it is impacting tissue, what is it doing to metal objects, electronics, telecomm equipment?

Environmental Legislation and miniaturization makes electronics potentially more at risk for damage



Some Sobering Statistics

Although for the most part, the plant-floor metrics of facilities in the “2007 China Manufacturing Study” (conducted by the Manufacturing Performance Institute (MPI) resemble those of Western firms. One notable exception: China represents a disadvantage in customer reject rates. China has a median 50,000 parts per million (ppm), compared to 100 ppm in the U.S.

Time to Rethink China

by Grant Thornton LLP

October 5, 2009

World Trade 100 White Paper

A recent survey by Square Trade shows that 1 in 3 laptops die in the first 3 years of use (a survey by Square Trade on warranty issues for 30,000 laptops sold in a 3 year period).

20.4 percent of failures are due to hardware malfunctions. 10.6 percent are due to drops, spills, or other accidental damage. Corrosion has played a role.



The Environment Impacts Reliability

- Reliability of electronics / components / systems is impacted by many factors
- Some factors we can easily control by controlling the environment that we manufacture parts in
- However, it is difficult to manage the environment where parts are shipped, stored or put into application
- What risk factors are we exposing our electronics to?
 - Atmospheric Pollution / Biological Attack / ESD Damage
 - Humidity / Gases
 - Volatiles in Packaging / Dust



The snow on the west side of Mount Hood is now grey

The east side remains white - **Pollution is not regional with Air streams...**

Corrosion has recently become a more significant factor in the reliability of electronic devices and components, reliability of assembled equipment, and even the reliability and performance of turbine equipment and heavy earth moving equipment. The world is increasingly more polluted and current packaging schemes are not keeping pace with the changes.



Some Corrosive Gases of Most Concern

- Nitrous Oxides (**NO_x**)
 - Effluent from gas powered forklift trucks, etc.
- Ozone (**O₃**) - reactive oxygen
 - Ozone acts as an accelerant making corrosion happen faster
- Hydrogen Sulfide (**H₂S**) and Sulfur Dioxides (**SO₂**)
 - H₂S is the bigger concern it is 10X more reactive than SO₂
 - SO₂ needs dust particles or dirt in the air to be reactive – why Asia is having a greater issue with SO₂ than NAR
- Carbonyl Sulfide (**COS**)
 - (very prevalent on oceans)
- Hydrogen Chloride (**HCl**)



H₂S Levels - Worldwide

- Average H₂S level in US
 - Europe
 - Brazil (Brasil)
 - Average Level of H₂S outdoor (Shanghai)
 - H₂S found inside electronic manufacturing plants – Suzhou
- 7 ppb
 - 15 ppb
 - 640 ppb
 - 800 ppb
 - 1500 ppb

... an aerial view of the Asian Corrosion Issue

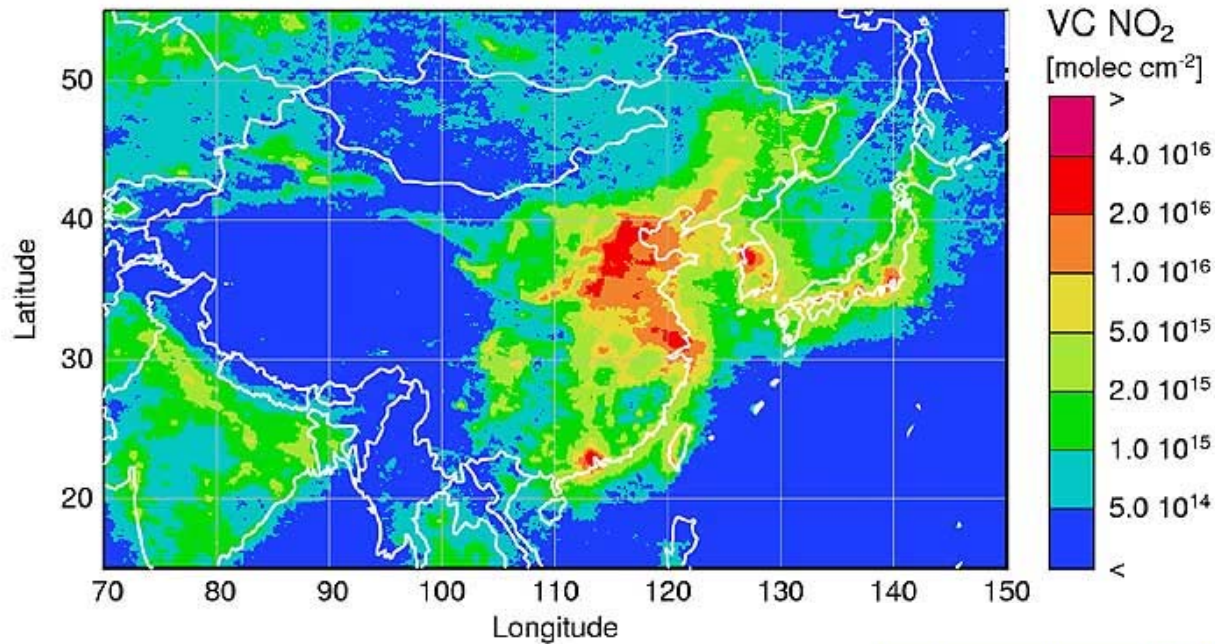

Europe is not excluded from the growing level of atmospheric pollution

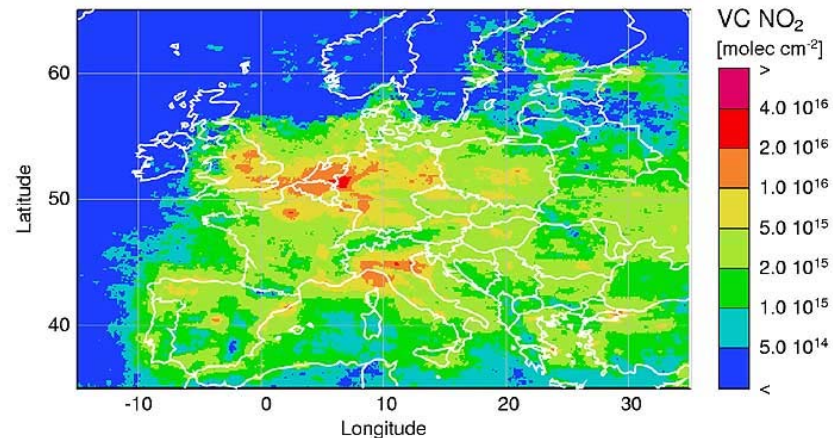

Sometimes Reliability Issues are Easy to Identify... in the Field



Cell Site down and out

Sometimes Reliability Issues are Easy to Identify - knowing failure points



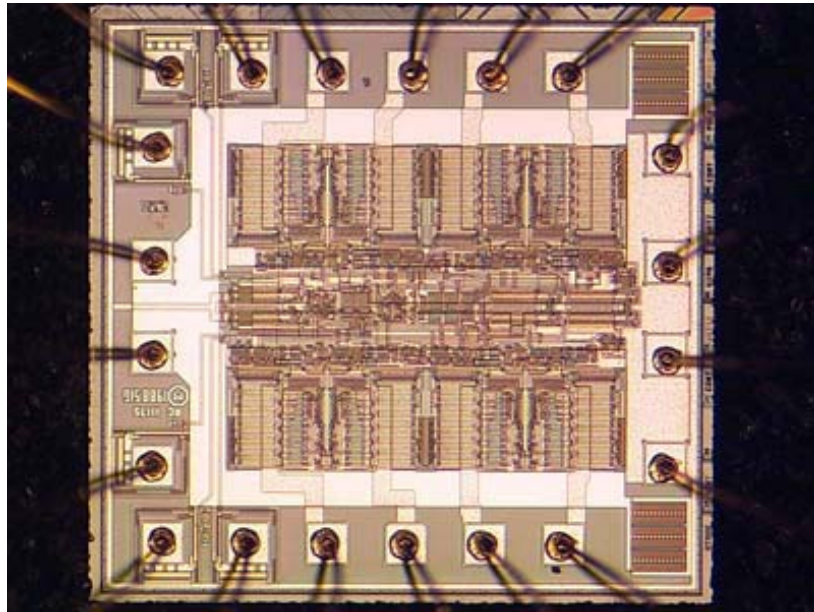

Sometimes the complexity or size of the component / part makes identifying problems difficult



6 weeks in Standard ESD Bags in India



Recent Review of Crates by a customer in Costa Rica

- Recent survey of high end electronic equipment in Costa Rica, where they had been told that no corrosion issues existed
- Tools in the crates had been packed in foil
- Every tool opened and reviewed showed some signs of corrosion and some mold damage as well
- Foil is a passive barrier – it only works with 100% Hermetic seal and RH levels less than 37%
 - A pin hole / nail hole will make foil ineffective and fail
 - Foil has limitations and can fail



Mold, Mildew and Bacteria

- Many molds and mildews secrete sulfur as a byproduct of respiration
- General Dynamics in the UK has seen an increase in the bio-burden on the electronics coming in from Asia (higher numbers of bacteria, mold, mildew)
 - Experiments were done with new boards coming in from Asia still in their original packaging
 - Bacteria and mold/mildew cannot reproduce in the presence of Copper
 - Intercept has been shown to kill bacteria and the bio-loading coming in on electronics
 - Shielding bags nor foil have no ability to kill mold, mildew or bacteria

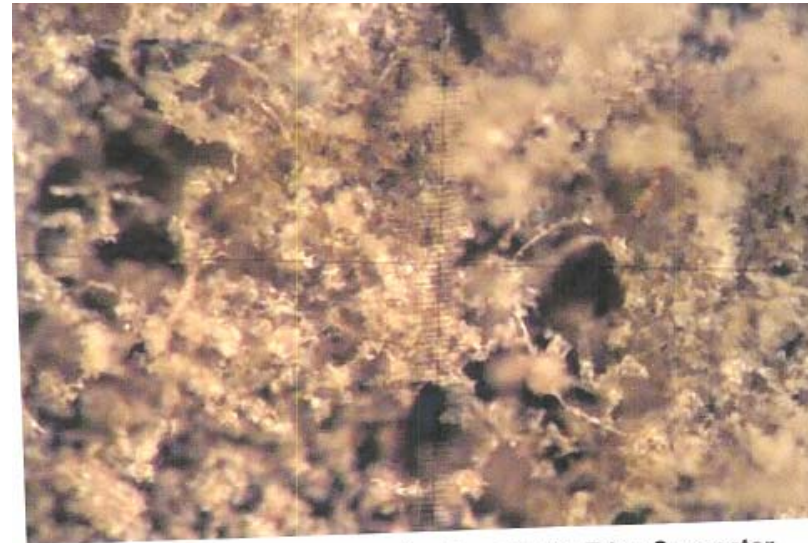
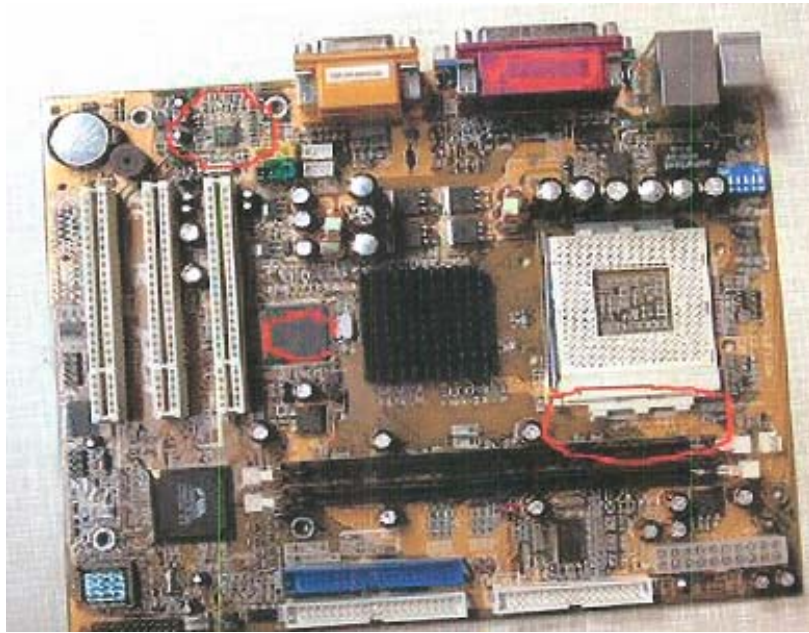
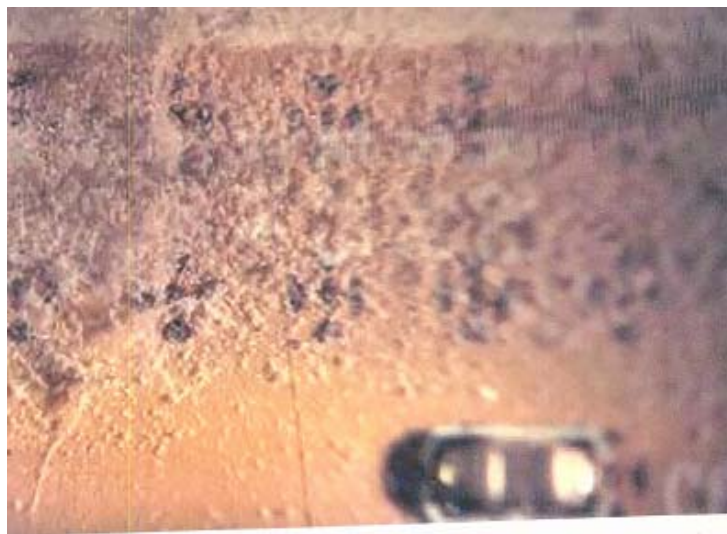

Figure 2 Severe Contamination On The Edge Connector



Extensive Fungal Growth close to passive components



***Aspergillus terreus* growing on label adhesive**



Corrosion and Electronics

- How does **Corrosion** damage show up in electronic devices, components, etc.?
 - **Latent Defects**
 - **Soldering Problems**
 - **Low Yield**
 - **Increased Resistance**
 - **Reduction in Performance**
 - **Poor Connections**
 - **Physical Discoloration, Staining**
 - **Contamination**

RoHS and Worsening Environment

Based on actual shipment, RoHS compliant PWB with Via junction corrosion damage. Here an example of a board in storage 6 weeks in India. China would be worse.

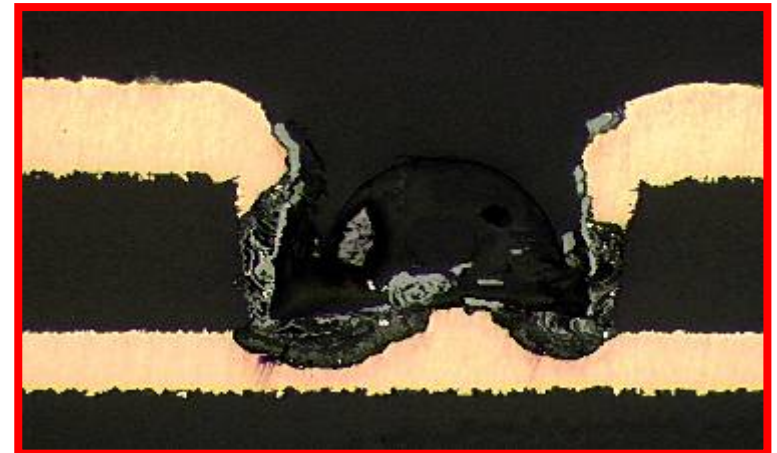
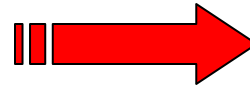
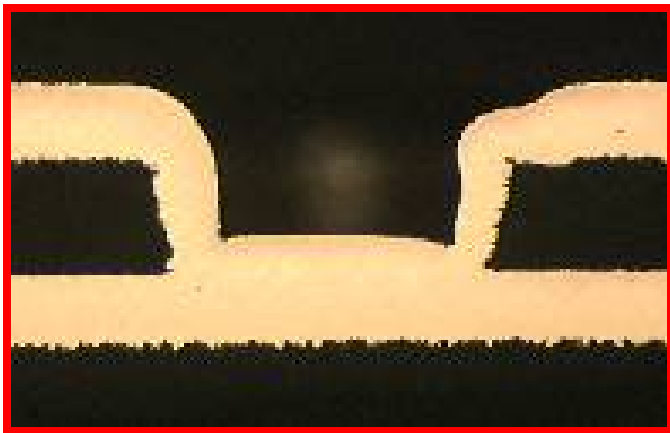

It was not the act of ESD
It was corrosion
H₂S in the environment literally ate away the via

Real World Reliability Example

- 3 month old laptop
 - Deployed in NAR for only 3 months
- Hard drive manufactured in Thailand
- The board was nearly dead from delivery due to pollution during manufacturing / shipment in Asia

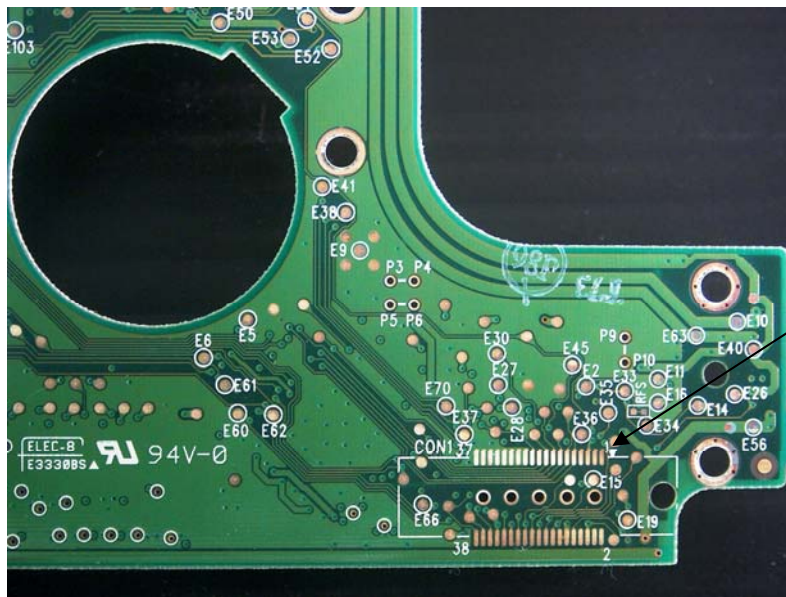

Gross
Corrosion
On the
Silver

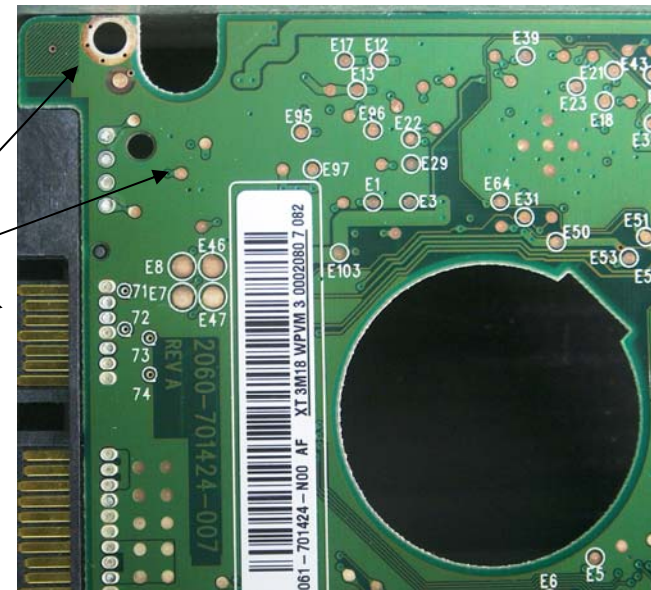

Controller After 2 Weeks in Standard Packaging – South Africa

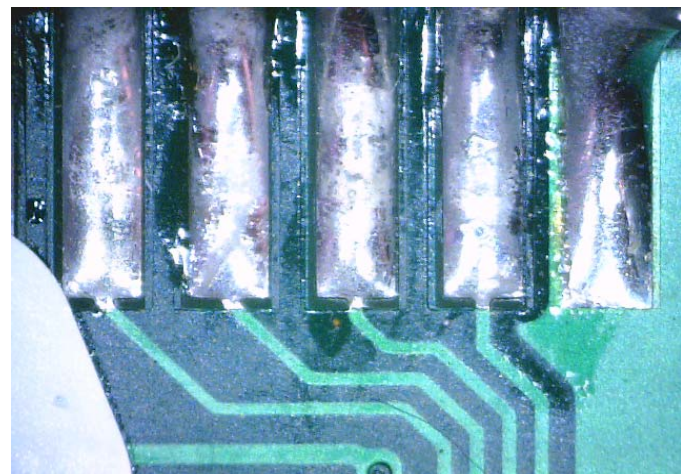
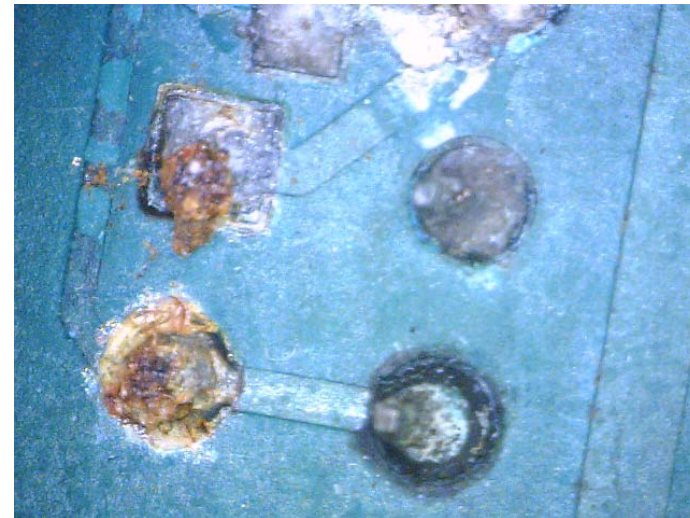
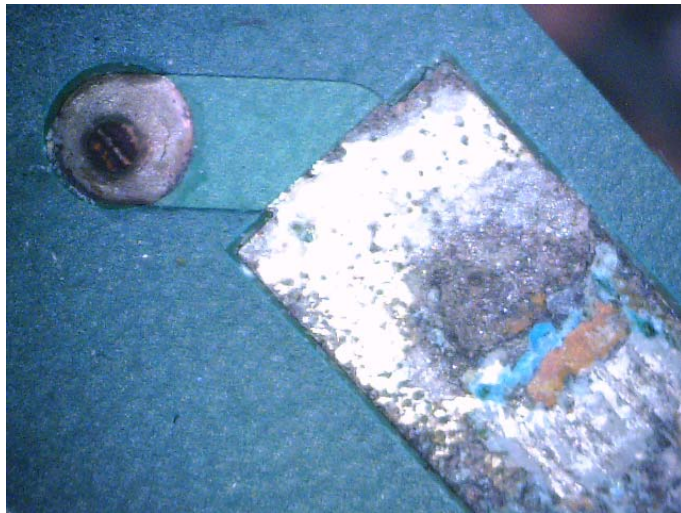

Take a perfectly functioning controller and store it, in its original packaging near the ocean in South Africa and your customer may get an unexpected surprise

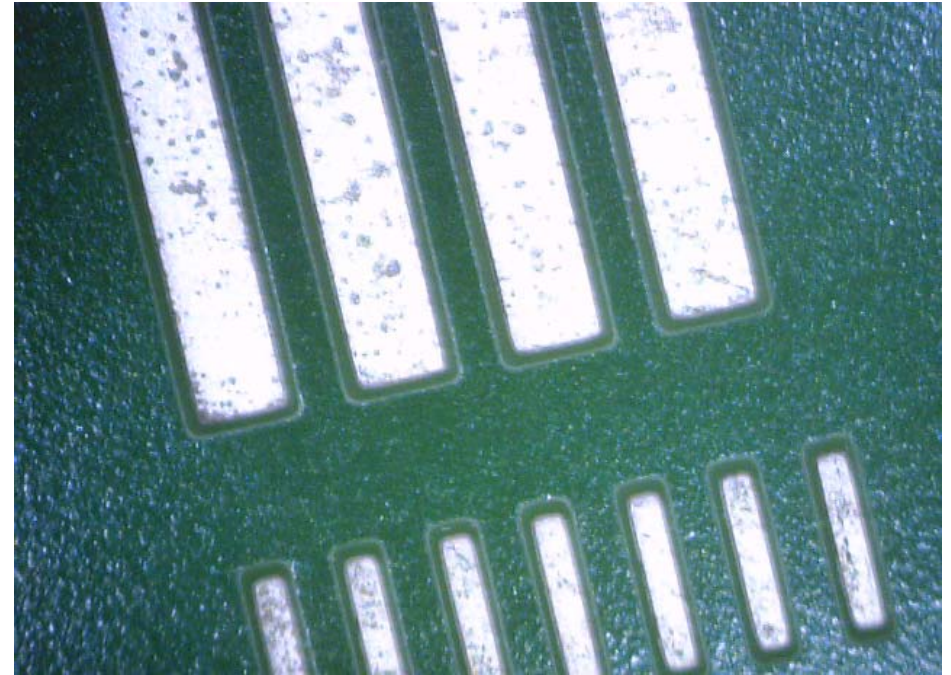
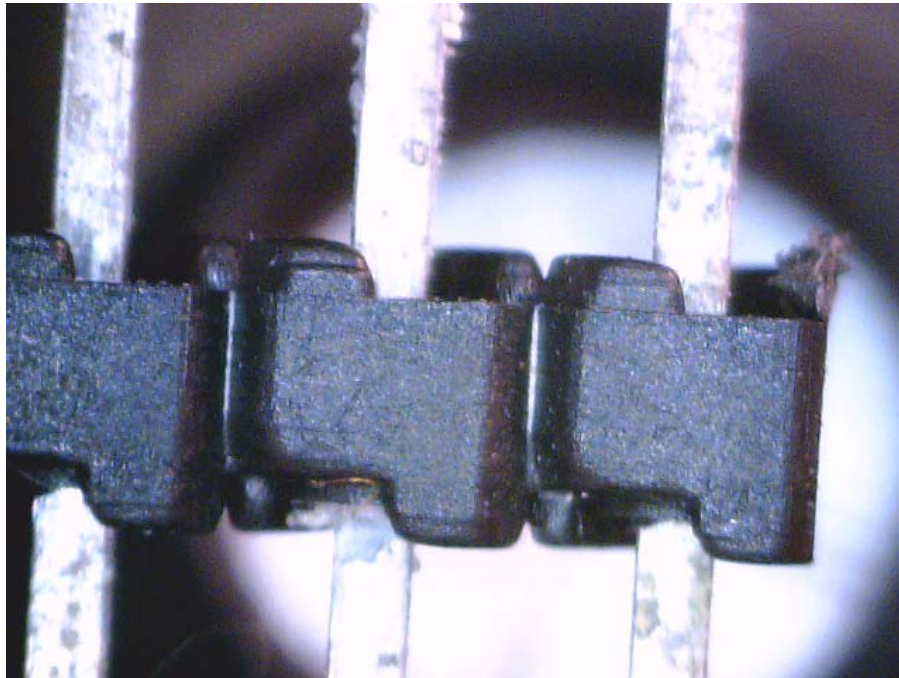

3 Weeks in China in a standard ESD Bag

Corrosion not only increases resistance of the metal, potentially over-stressing (remember EOS), it also destroys contacts, solderability and decreases functionality

Packaging can make a Difference

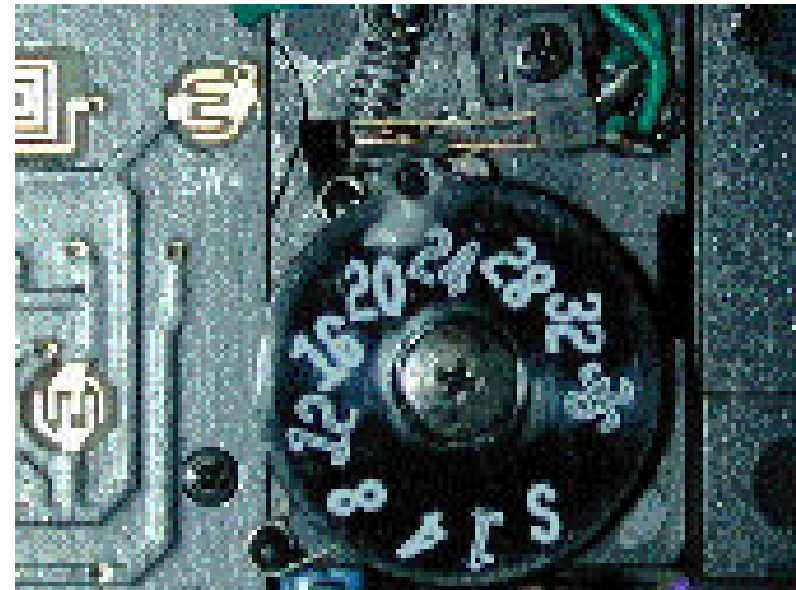
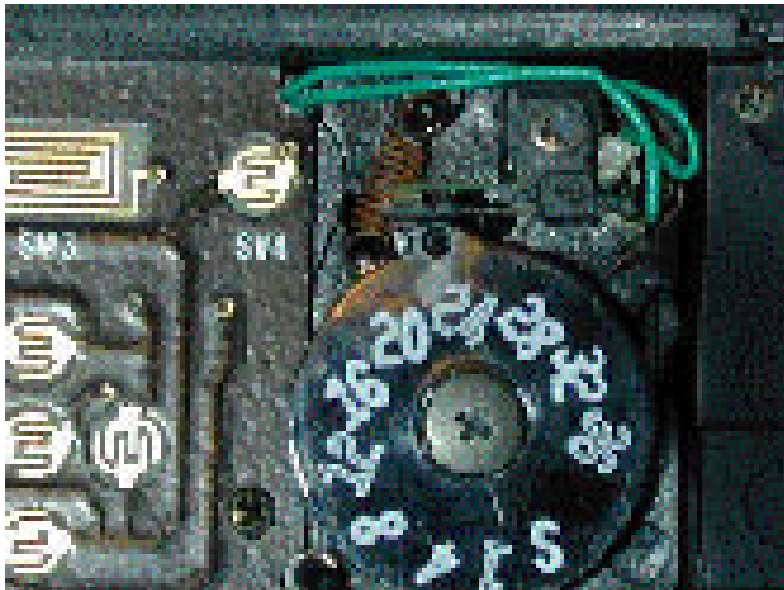

The camera on the left had traditional packaging, the camera on the right had new packaging that was designed to improve reliability.

Notice: steel part corrosion / plastic breakdown / undercoat corrosion

Solving one problem, can create another one somewhere else...



Foil bags / Shielding bags are not recyclable in Europe, even in Canada there are issues with disposing of foil bags





Lead-Free Printed Circuit Board Finishes

With SnPb soldering processes HASL [SnPb] has been the predominant board finish followed by NiAu and OSP. The following represent the most common board finishes to consider for a lead-free process.

Board Finish	Comment
Electroless Ni / Immersion Au	Recommended in JEITA Pb-free roadmap and predominant in Japan and EU. Highest cost process, but good corrosion resistance for on-board contact pads and suitable for wire bonding pads for COB designs.
HASL [SnAgCu or SnCu]	Recommended in JEITA Pb-free roadmap and commonly used in Japan.
OSP	High volume, low cost alternative. Commonly used. Solderability more easily degraded by multiple reflows.
Immersion Ag	Good solderability and an increasingly significant board finish.
Immersion Sn	Commonly used in EU. Presence of carcinogenic thiourea in solutions has limited its use in USA.



Board Finishes

All preserve
fine line detail

Immersion Silver (ImAg) ** The Preferred Choice, if...**

Silver is applied to the copper by an immersion plating process.

- Low cost
- Compliant with all component finishes
- Corrodes (Tarnishes)

Immersion Tin (ImSn)

Tin is applied to the copper by an immersion plating process.

- Low cost
- Compliant with most component finishes
- Corrosion Resistant
- Forms Tin whiskers causing unpredictable shorting

Immersion Gold (ImAu)

Gold is applied to the copper by an immersion plating process.

- High cost
- Compliant with most component finishes
- Corrosion Resistant
- Forms Black Pad syndrome causing unpredictable failures

RoHS Compliance - Silver

Tests / Investigations

Samples protected in Shielding bags

Corrosion / Contamination on the surface of Silver Coupon did not allow acceptable soldering

Comparison run simultaneously but protected in Intercept

Perfect solder lines



Samples sealed in Brand X bags



Figure 43 Coupon #16.



Figure 44 Coupon #17.



Figure 45 Coupon #18.



Figure 46 Coupon #19.

Samples sealed in Intercept® bags



Figure 33 Coupon #1.



Figure 34 Coupon #2.



Figure 35 Coupon #3.



Figure 36 Coupon #4.

Courtesy of American Competitive Institute 2005



SUB-MICROMETER ORDER CORROSION OF SILVER BY SULFUR VAPOR IN AIR STUDIED BY MEANS OF QUARTZ CRYSTAL MICROBALANCE

Jun'ichi SAKAI from Waseda University Tokyo, JAPAN

Paper presented at 16th International Corrosion Congress in Beijing, China 2005

The purpose of this study is to clarify the effect of temperature ($T = 30-75$), relative humidity ($RH = 10-100\%$) and distance between sulfur source and silver surface ($l = 1-12$ cm) on sub-micron order corrosion of silver during exposure to sulfur vapor

The independence of the corrosion rate on relative humidity indicates that free sulfur directly reacts with silver and moisture does not play a major role in corrosion of electronic materials.

RoHS - Compliance

Solderability Test



Control:
100% Coverage

17 Years in INTERCEPT:
95% Coverage
Even with no cleaning
On the parts tested

**6 Months Asia:
Packed in standard
Shielding Bag Packaging**
No Solder Coverage



Apex Paper by Boeing

- Airbus industries issued a technical follow up bulletin (number 212600011) concerning problems with dust causing failures of computer systems
- Examination of subject computers revealed failure to be caused by intermittent internal computer board short circuits due to the presence of hygroscopic conductive dust inside the computer – as the dust hydrates they become conductive allowing for shorts.



Packaging

- Growing regulatory and environmental concerns on packaging
 - Currently European legislation makes plastics with >100 ml of oil on/in 1 m³ of film non-recyclable, later this year the level drops to 40 ml (1.3 ounces)
 - Foil bags as well as Shielding Bags are non-recyclable which has European implications
 - Sustainable / recyclable / re-usable are no longer catch phrases, they are the standards that are beginning to be demanded
 - European legislation against volatile substances in packaging, including TRGS-615
- Consolidation of European environmental laws, now with the EU Constitution being ratified will begin to take place
- Already two additional items added to RoHS list in EU
- Green Packaging is the new push around the globe



Environmental Legislation Also Hits US

North America

California has passed SB 20: Electronic Waste Recycling Act of 2003, or [EWRA](#). This law prohibits the sale of electronic devices after January 1, 2007, that are prohibited from being sold under the EU RoHS directive, but across a much narrower scope that includes LCDs, CRTs, and the like and only covers the four heavy metals restricted by RoHS. EWRA also has a restricted material disclosure requirement.

Effective January 1, 2010, the California Lighting Efficiency and Toxics Reduction Act applies RoHS to general purpose lights, i.e. "lamps, bulbs, tubes, or other electric devices that provide functional illumination for indoor residential, indoor commercial, and outdoor use."[\[23\]](#)

Other US states and cities are debating whether to adopt similar laws, and there are several states that have mercury and PBDE bans already.



Preservation Methods

- Dry Packaging (Foil) – Passive Barrier
 - MVTR is key
 - Developed by the Germans in the 1920's
 - If you keep Ferrous Metals at less than 37% humidity the surface will become passivated
 - Limitations:
 - Requires high barrier properties
 - Requires hermetic sealing, evacuation and desiccants
 - Does not work for Non-Ferrous metals
 - Does not work if you loose vacuum or if you have an incomplete seal or tear or pinhole in the packaging
 - Is not recyclable and difficult to re-seal for post QA
 - Cannot be repaired easily after customs opens it



Preservation Methods

- Shielding Bags
 - Do not provide MVTR or anti-corrosion properties
 - Developed by 3M in the 1970's
 - Metal in structures use ESD coatings on both inside on the poly surface and outside on the polyester surface – contain VOC's
 - Limitations:
 - Humidity dependent
 - Effective shelf / useful life reduced by time and temperature
 - Metal in structures can hold up to 560 volts of retained voltage
 - » Retained voltage is the energy required for the static electricity to bridge the PET layer to get to the metal layer in order to get to ground
 - They are not recyclable



There is an alternative

- The Intercept Technology™
 - Developed by Bell Labs to provide:
 - Permanent, humidity independent ESD protection
 - ESD protection with no volatiles
 - ESD protection that also provides long term, non-contaminating corrosion protection
 - Effective, long term (proven) solderability protection
 - Intercept is TRGS-615 compliant
 - Static Intercept® is the best ESD – Corrosion Protection material on the market today

Protection, Performance and
SMALLER Carbon Footprint

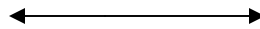

Static Intercept®

- Bags / Films / Totes
- Homogenous
- Recyclable / Re-usable
- No volatiles

Traditional ESD Packaging Static Shielding Bags

- Not recyclable
- Coatings (VOC) on inner and outer surfaces
- Lamination layer (adhesive + lamination step)
- Polyester Layer (high temperature extrusion)
- Vacuum deposited Al layer
- Polyethylene (PE) layer



Carbon Footprints

A Telecommunication company did an investigation as to how best to reduce their carbon footprint / impact on the environment

Operation	Static Intercept®	Shielding Bags / Foil
Manufacture (10" x 20" bag)	36 kg CO2 36 % reduction	56 kg CO2
Recyclable / Re-usable	Yes ~50% reduction	No
Improvement in Reliability	1% Improvement (circuit cards)	
Savings by not having to remake cards / longer life	40 times reduction (4000% reduction)	



Intercept Environmental Aspects

- Intercept helped VW to win 2 environmental awards by eliminating oiling their engine blocks – with huge cost savings
- Intercept was awarded an Environmental Award for Being an Environmentally Friendly Anti-Corrosion Packaging by the German Government
 - The only anti-corrosion packaging in Germany with this honor
- Intercept is RoHS compliant and keeps Silver from tarnishing so as to help RoHS compliant board finishes to stay pristine
- Intercept is fully recyclable / re-usable / VOC free / Volatile Free



Intercept Technology

- Solves Corrosion problems causing defects in electronics and assemblies
- Replaces **FOIL BARRIER and/or Shielding Bag** packaging and traditional corrosion prevention systems – including volatile protection systems
- Is a reactive barrier system, not a passive system like foil systems or volatile systems
- Is inherently clean - avoids contamination of sensitive components
- Provides passive mildew protection
- Provides protection for surfaces to be painted

Examples of Re-Use

Small components to large dunnage systems can be re-used, reducing cost and clutter



Fuel injectors – small vacuum formed tray that took a corrosion critical part from 300% inspection to 200% and one way packaging to over 3 years use with no failures



Engine block bags for shipments between continents and storage

Going Green Saves More than the Environment



A major automotive supplier in Japan has switched from a shielding bag (non-recyclable) and a RP oxygen absorber, cost 80 yen. The system is a 1 time use.

New system is an Intercept tray with 7 time re-use. The cost is 300 yen. The savings per year is a minimum of 27,000,000 Yen.

18 months of trials – no rejects

Intercept® - flexibility and variety....

- Static Intercept comes in many forms

- 3 mil film and bags
 - This is our stock items
 - For most applications

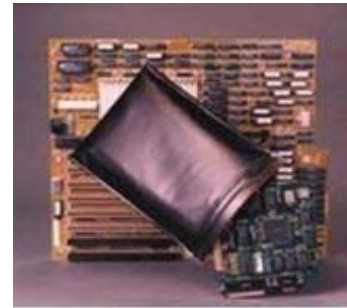

- 4 mil film and bags
 - For export shipment
 - For Long Term Storage
 - Should be used for any customer testing



- Shrink Film (7 and 8 mil)
 - For outdoor applications



- Totes (heavy gauge sheet)



Intercept Technology™ Available Worldwide

Americas / Asia

www.StaticIntercept.com

www.LibertyPackaging.com

www.Intercept-Technology.com

Europe/India